



# Electrolux

## Modular Cooking Range Line 700XP 2 Hot Plate Electric Induction Cooking Top Range

ITEM # \_\_\_\_\_

MODEL # \_\_\_\_\_

NAME # \_\_\_\_\_

SIS # \_\_\_\_\_

AIA # \_\_\_\_\_



Modular Cooking Range Line

700XP 2 Hot Plate Electric Induction Cooking  
Top Range

**371020 (E71NED2000)**      700XP 2 ZONE HOT PLATE  
ELECTRIC INDUCTION  
COOKING TOP RANGE -  
400 V

**371131 (E71NED200N)**      700XP 2 ZONE HOT PLATE  
ELECTRIC INDUCTION  
COOKING TOP RANGE -  
230 V

### Short Form Specification

**Item No.** \_\_\_\_\_

6 mm thick glass ceramic cooking surface with 2 independently controlled 3.5 kW induction zones. Induction top surface with seamless transition between individual heating zones. Exterior panels in stainless steel with Scotch Brite finish. One piece pressed work top in 1.5 mm thick stainless steel. Right-angled side edges to allow flush-fitting junction between units.

### Main Features

- 6mm glass ceramic cooking surface with 2 independently controlled induction zones with a power of 3.5 kW per zone.
- Almost the entire surface of the ceramic plate can be used without "dead" spots.
- Indicating lamp for each zone located on control console.
- Induction plates endowed with overheating safety device.
- Power to the individual zones can be set with progressive output i.e. fine regulation at the lower and larger progress at the upper levels.
- Low heat dissipation to the kitchen.
- The smooth, glass ceramic plate is not directly heated, so there is no burning on cooking surface.
- IPX 4 water protection.

### Construction

- All exterior panels in Stainless Steel with Scotch Brite finishing.
- One piece pressed 1.5 mm work top in Stainless steel.
- Model has right-angled side edges to allow flush fitting joints between units, eliminating gaps and possible dirt traps.

### Optional Accessories

- 4 wheels, 2 swivelling with brake PNC 206135   
(700/900XP). It is mandatory to install with base supports for feet/wheels.
- Support for bridge type system, 800mm PNC 206137
- Support for bridge type system, 1000mm PNC 206138
- Support for bridge type system, 1200mm PNC 206139
- Support for bridge type system, 1400mm PNC 206140
- Support for bridge type system, 1600mm PNC 206141
- Support for bridge type system, 400mm PNC 206154
- Water coulum with swivel arm (water column extension not included) PNC 206289
- Water column extension for 700 line PNC 206291
- Chimney upstand, 400mm PNC 206303
- Base support for feet or wheels - 400mm (700/900XP) PNC 206366

APPROVAL: \_\_\_\_\_



Electrolux

700XP 2 Hot Plate Electric Induction Cooking Top Range  
Modular Cooking Range Line

- Base support for feet or wheels - 800mm (700/900)  PNC 206367
- Rear paneling - 600mm (700/900XP)  PNC 206373
- Rear paneling - 800mm (700/900)  PNC 206374
- Rear paneling - 1000mm (700/900)  PNC 206375
- Rear paneling - 1200mm (700/900)  PNC 206376
- Chimney grid net, 400mm  PNC 206400
- 2 side covering panels for top appliances  PNC 216277
- Stainless steel universal frying pan with stainless steel handle (diam. 200mm) suitable for induction and all other heating sources (only for 371020)  PNC 653596
- Universal frying pan with stainless steel handle (diam. 240mm) suitable for induction and all other heating sources (only for 371020)  PNC 653597
- Universal frying pan with stainless steel handle (diam. 280mm) suitable for induction and all other heating sources (only for 371020)  PNC 653598

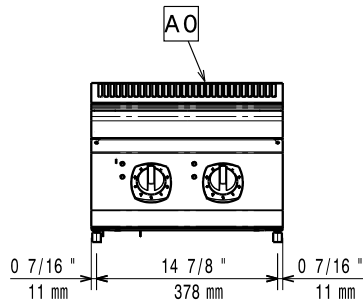
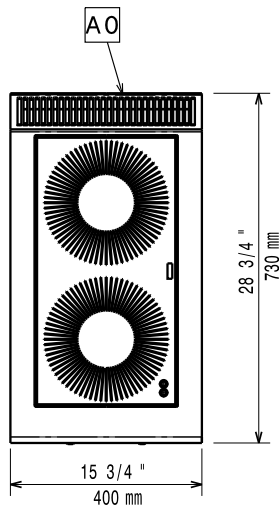
**Front**

**Top**

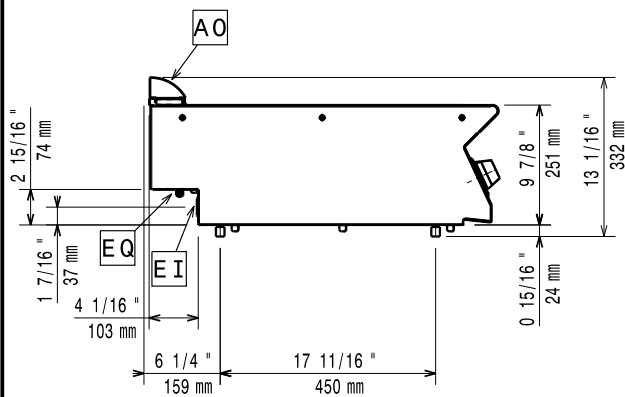
EI = Electrical connection  
EQ = Equipotential screw

**Side**

## Electric

### Supply voltage:

371020 (E7INED2000)	400 V/3 ph/50/60 Hz
371131 (E7INED200N)	230 V/3 ph/50/60 Hz

### Total Watts:

7 kW

## Key Information

### Induction Top Dimensions

(width): 400 mm

### Induction Top Dimensions

(depth): 730 mm

### Net weight:

20 kg

### Shipping weight:

371020 (E7INED2000) 34 kg

371131 (E7INED200N) 27 kg

### Shipping height:

540 mm

### Shipping width:

460 mm

### Shipping depth:

820 mm

### Shipping volume:

0.2 m<sup>3</sup>

If appliance is set up or next to or against temperature sensitive furniture or similar, a safety gap of approximately 150 mm should be maintained or some form of heat insulation fitted.

Induction compatible pots & pans must be used.